

Lecture 17

Source

Prof Peter YK Cheung
Dyson School of Design Engineering

URL: www.ee.ic.ac.uk/pcheung/teaching/DE1_EE/
E-mail: p.cheung@imperial.ac.uk



In this lecture, we will look at how we supply energy to electronic circuits (source) and how such energy is dissipated in circuits.

Electrical Energy and Power

- ◆ Electrical Energy $E = QV$.
- ◆ Electrical Energy is measured in joules (J), electrical charge Q is measured in coulombs (C) and electrical potential V is measured in volts (V).
- ◆ Power is the rate at which electrical energy moves or is used. It is measured in watt (W).
- ◆ For DC power source such as batteries, and assuming that the current draw is constant, electrical power is calculated easily with:
$$P = dE/dt = V dQ/dt = V \times I.$$
- ◆ One joule per second is equal to one watt.
- ◆ The Intel i5 processor (Jan 2015 Broadwell-U) draws around 15W of power.
- ◆ The LED you use in the circuit in Task 1 of Lab 4 draws around 7mA from the 5V supply. It used 35mW of power.
- ◆ The cost of electricity (i.e. what we have to pay) is Power x Time
- ◆ If you leave a 40W light bulb on for one day (24 hours), you use and have to pay for about 1kW hr.

We have had a brief look at energy and power in electrical circuits in earlier lecture. Here is a reminder of some of the basic definition of electrical energy and electrical power.

1 joule of electrical energy is the energy required to move 1 coulomb of charge through an electrical potential of 1 volt.

Electrical power is energy used per second, i.e. Energy/time. Therefore if you consider power dissipated in a circuit only using DC voltage source and the current is essentially constant, then Power = $V \times I$ which is pretty straightforward. 1 watt is using 1 J of energy per second.

It is worth putting some physical meaning to these. A traditional incandescent light bulb at home would dissipate around 40W to 60W. Therefore 1W is pretty small.

The i5 processor inside your laptop dissipates 15W, which is already low as compared with the power hungry desktop version that could draw as much as 50W.

However the LED you used in Lab 4 Task 1 (because of the 330Ω resistor you used in series) has a current of around 7mA from the 5V power source, therefore in total draws only 35mW.

Your electricity bill at home shows that the electricity company is charging you for the energy you used (i.e. Power x Time) and the unit is measured in kilowatt-hour. The cost is around 15p or so. That's how much you would pay if you leave your 40W light bulb on for a full day!

Power in AC circuits

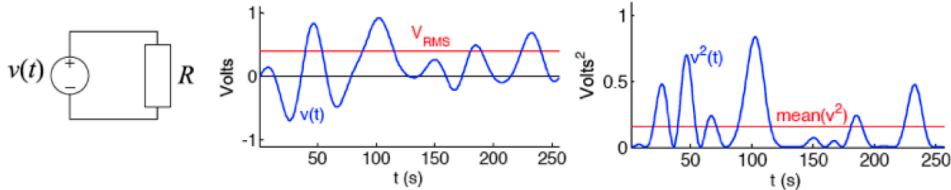

- ◆ Consider the simple AC circuit above.
- ◆ **Instantaneous Power** dissipated in R: $p(t) = \frac{v^2(t)}{R}$
- ◆ **Average Power** dissipated in R: $P = \frac{1}{T} \int_0^T p(t) dt = \frac{1}{R} \times \frac{1}{T} \int_0^T v^2(t) dt = \frac{\langle v^2 \rangle}{R}$
 $\langle v^2 \rangle$ is the value of $v^2(t)$ averaged over time
- ◆ We define the **RMS Voltage** (Root Mean Square): $V_{rms} = \sqrt{\langle v^2 \rangle}$
- ◆ The average power dissipated in R is $P = \frac{\langle v^2 \rangle}{R} = \frac{(V_{rms})^2}{R}$
- ◆ V_{rms} is the DC voltage that would cause R to dissipate the same power.
- ◆ We use *small letters* for time-varying voltages and **CAPITAL letters** for time-invariant values.

Cosine Wave RMS

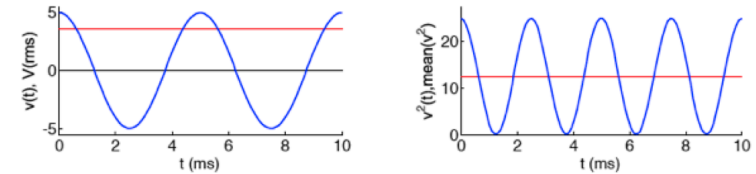

- ◆ **Cosine Wave:** $v(t) = 5 \cos \omega t$. Amplitude is $V = 5$ V.
- ◆ **Squared Voltage:** $v^2(t) = V^2 \cos^2 \omega t = V^2 \left(\frac{1}{2} + \frac{1}{2} \cos 2\omega t \right)$
- ◆ **Mean Square Voltage:** $\langle v^2 \rangle = \frac{V^2}{2}$ since $\cos 2\omega t$ averages to zero.
- ◆ **RMS Voltage:** $V_{rms} = \sqrt{\langle v^2 \rangle} = \frac{1}{\sqrt{2}} V = 3.54$ V = \tilde{V}

Note: Power engineers always use RMS voltages and currents exclusively and omit the "rms" subscript.
 For example UK Mains voltage = 230 V rms = 325 V peak.

When it comes to AC signals, calculating power and energy is more complicated.

Take the circuit above, $v(t)$ is a simple AC voltage source driving a resistor R. $v(t)$ does not need to be sinusoidal, but goes up and down as shown in the diagram here.

To consider the power dissipated in the resistor R, we need to define the quantity instantaneous power $p(t)$, which is a function of time.

Since power = voltage x current, or $p(t) = v(t) * i(t)$ (note that I use lower case to indicate these are time varying quantities), $p(t) = v(t)^2 / R$.

You can use simple integration to calculate the average power dissipated in R over a period of time. The energy dissipated by R in time duration dt is $p(t) dt$. Therefore over the period of 0 to T, we can perform this integration to get the total energy used and divide this by T to get the average power.

Finally, we define RMS (root mean square) voltage the square root of the average of $v(t)^2$. RMS voltage is useful because it tells us how much power is consumed by just squaring this value and divide by R. It is the DC voltage that would cause R to dissipate the same power as with the AC signal $v(t)$.

Now let us consider a sinusoidal signal.

Here are the four important measures for a cosine signal with amplitude of 5V.

Remember that the frequency of the signal does not affect the mean square or root mean square voltages.

In the UK, the mains power (i.e. the AC power line coming from the wall sockets) are quoted as 230V +10% and -6% (nominally it is 240V at 50Hz). In fact this value is RMS, not amplitude (peak). The peak value is $\sqrt{2} \times 230 = 325$ V.

Sourcing Energy from AC Mains

- ◆ All electronic circuits need a power source to work.
- ◆ For electronic circuits made up of transistors and/or ICs, this power source must be a DC voltage of a specific value.
- ◆ A battery is a common DC voltage source for some types of electronic equipment especially portables like cell phones and iPods.
- ◆ Most non-portable equipment uses power supplies that operate from the AC power line but produce one or more DC outputs.
- ◆ The input is the 240 volt 50 Hz AC power line.
- ◆ The power supply converts the AC into DC and provides one or more DC output voltages.
- ◆ Some modern electronic circuits need two or more different voltages.
- ◆ A good example of a modern power supply is the one inside a PC that furnishes 12, 5, 3.3 and 1.2 volts.

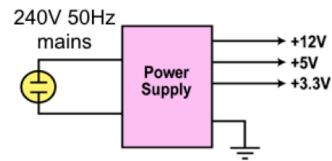

The purpose of this lecture is to consider where the power that drives our electric circuits come from.

While mobile electronics are driven by batteries, most other electrical equipment and appliances are driven by AC mains. It is far cheaper to use AC to deliver 1 W of power than to do the same from a battery. If you are using a rechargeable battery, you still have to recharge the battery using AC mains as a power source.

Modern power supply takes the 240V 50Hz mains and converts this to multiple DC voltages to drive our electronic circuits. For example, a typical PC power supply unit (inside your desktop or your laptop) provides four DC voltages: 12V, 5V, 3.3V and 1.2V..

AC supply to unregulated DC

- ◆ Convert AC to DC using diode rectifier circuit.

- ◆ The simplest form of rectifier is the half wave rectifier shown.

- ◆ The half wave rectifier produces one sine pulse for each cycle of the input sine wave.

- ◆ When the sine wave goes positive, the anode of the diode goes positive causing the diode to be forward biased. The diode conducts and acts like a closed switch letting the positive pulse of the sine wave to appear across the load resistor.

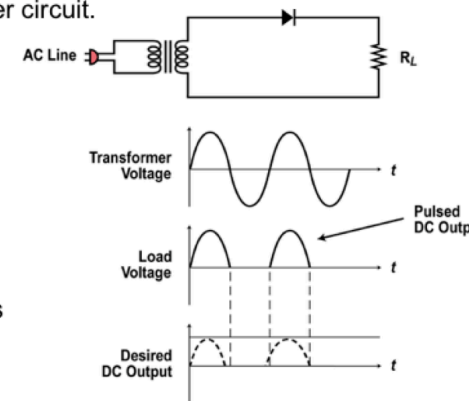

- ◆ When the sine wave goes negative, the diode anode will be negative so the diode will be reverse biased and no current will flow.

- ◆ No negative voltage will appear across the load. The load voltage will be zero during the time of the negative half cycle.

How is a 240V AC supply converted to a DC voltage?

Firstly let us consider the idea of "rectification". What this mean is that we first remove the negative portion of the sinusoidal AC voltage using a diode. Since the diode can only conduct electricity in one direction (the direction of the "arrow" in the symbol), the voltage across R in the circuit above only has the positive half of each cycle.

One may use a transformer (shown as two coupled inductor in the circuit diagram) in order to do two things: 1) provide isolation between the AC mains and your circuits through magnetic coupling; 2) using different number of turns in the primary (mains) and the second (your circuit) side of the transformer, you can reduce the the AC amplitude from the very large 325V.

A better circuit - the full wave rectifier

- ◆ Another widely used rectifier is the bridge rectifier. It uses four diodes.
- ◆ This is called a full wave rectifier as it produces an output pulse for each half cycle of the input sine wave.
- ◆ On the positive half cycle of the input sine wave, diodes D1 and D2 are forward biased so act as closed switches appearing in series with the load.
- ◆ On the negative half cycle, diode D1 and D2 are reverse biased and diodes D3 and D4 are forward biased so current flows through the load in the same direction.

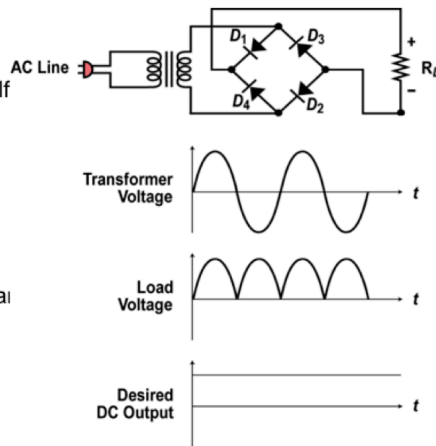

Although the simple one diode circuit works, it is not very efficient because you are only drawing current the mains supply half of the time.

Most power supply now use a four diode circuit known as a bridge rectifier.

Tracing through this circuit, it is clear that on the positive cycle of the sinewave, D1 and D2 conduct. During the negative half of the cycle, D3 and D4 conduct. In both cases, the +ve terminal of RL is driven high relative to the -ve terminal. Both half cycles are now made positive as shown here.

AC Mains to unregulated DC

- ◆ A large capacitor is connected across the load resistor. This capacitor filters the pulses into a more constant DC.
- ◆ When the diode conducts, the capacitor charges up to the peak of the sine wave.
- ◆ Then when the sine voltage drops, the charge on the capacitor remains. Since the capacitor is large it forms a long time constant with the load resistor. The capacitor slowly discharges into the load maintaining a more constant output.
- ◆ The next positive pulse comes along recharging the capacitor and the process continues.

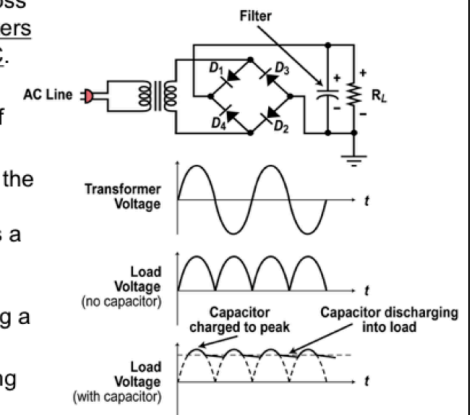

We want to convert this humpy rectified sinewave to a DC voltage. For that we use a capacitor.

The capacitor does a good job of smoothing the pulses from the rectifier into a more constant DC.

A small variation occurs in the DC because the capacitor discharges a small amount between the positive and negative pulses. Then it recharges. This variation is called ripple.

The ripple can be reduced further by making the capacitor larger.

The ripple appears to be a sawtooth shaped AC variation riding on the DC output.

A small amount of ripple can be tolerated in some circuits but the lower the better overall.

Basic idea of DC-DC down converter

- ◆ Uses a switching regulator (implemented using a transistor) to switch the unregulated voltage V_i to an averaging circuit.
- ◆ The output voltage is controlled by the duty-cycle of the switch.
- ◆ We then use an averaging circuit to 'smooth' output.

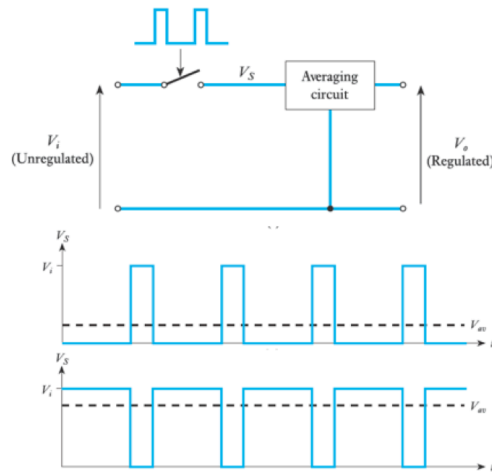

Even after using the full-wave rectifier circuit and the averaging capacitor, we still have to convert whatever DC voltage at the output to the desirable DC voltage. For that we use our old trusted PWM principle again.

By adjusting the duty cycle of the switch control signal, we can turn the switch on and off for exactly the correct duration in order to get the desired DC output.

In the plots here, we shown two scenarios for a low and high output voltage.

Details of the DC-to-DC down converter

- ◆ This circuit (also known as a Buck Converter) converts a high voltage, V , into a lower one, Y .
- ◆ The switch, S , is controlled by a PWM signal. It closes for a fraction a of the time. a is the *duty cycle* and is $1/3$ in this example.
- ◆ **When S is closed**, $x = v$, and a current i_L flows.
- ◆ **When S opens**, the current i_L cannot change instantly and so it must flow through the diode (we assume the diode is ideal).
- ◆ The average value of x is $aV \Rightarrow$ the average value of y must also be aV .
- ◆ The average current through R is aV/R so, since the average current through C must be zero, the average current i_L must also be aV/R .
- ◆ $C \frac{dy}{dt} = i_L - i_R \Rightarrow$ if C is large, then the variation in y will be very small.

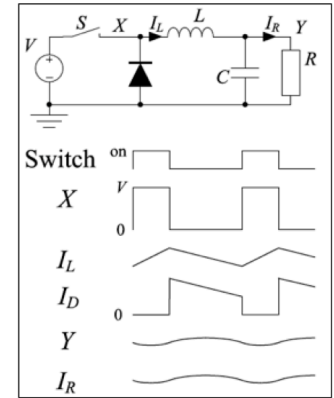

The averaging circuit typically consists of an inductor in series, and a capacitor in parallel to the load R .

The waveforms here shows what is happening.

When S is closed, the unregulated voltage V is supplied to one end of the inductor. Assuming that the output voltage Y is more or less constant, the voltage across L is also constant. Therefore the current i_L is the integral of the voltage across L and it takes a triangular shape.

This is current will charge and discharge the capacitor C and gives a further smoothed output voltage Y . (Remember the smoothing effect of a capacitor on a varying voltage.)

The diode serves the same purpose as the diodes you found across the solenoid switching transistor or the motor driving H-bridge transistors. It is often given a colour name – the “fly-wheeling” diode. Don’t worry about the name. Its purpose is the limit the voltage spike in the circuit when S is turned OFF. Remember that current through an inductor cannot be changed suddenly. So if S if turn off, the diode provides a path for the current to flow – and this limit the voltage spike.

Battery Types

Disposable Batteries

- ◆ **Alkaline (all types of applications)**
- ◆ Zinc carbon (flashlights, toys)
- ◆ Heavy duty zinc chloride (radios, recorders)
- ◆ Lithium (photoflash)
- ◆ **Silver, mercury oxide (hearing aid, watches)**

Rechargeable Batteries

- ◆ **Lead acid**
- ◆ Alkaline
- ◆ Nickel cadmium
- ◆ Nickel metal hydride
- ◆ Lithium ion
- ◆ **Lithium ion polymer**

For mobile electronics, we need battery to provide the power source. Here are two lists of batteries: those that are disposable, and those that are rechargeable.

The details of materials used and why the electro-chemical properties of these batteries results in the different battery characteristics is beyond the scope of this course. However, it would be useful to know about the pros and cons of each battery type, and consider how to select the right battery for a given application.

The more popular battery types are highlighted in RED here.

Energy Density - Size and Volume

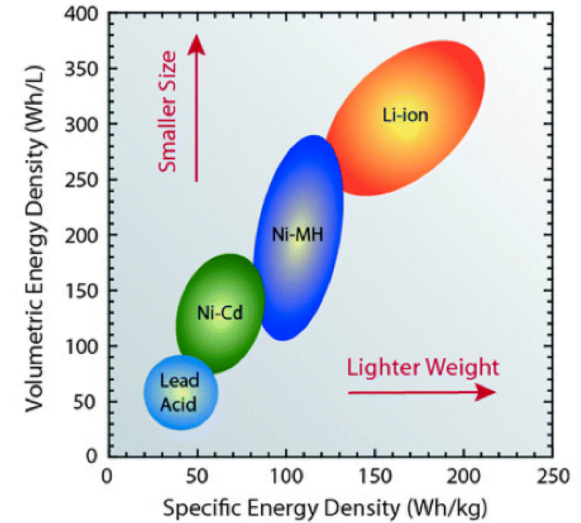

This plot shows how the four popular types of batteries vary in weight and size for a given battery capacity, which is normally measured in watt-hours. (If you have a fixed voltage, say 5V as in a USB compatible battery, the capacity can also be quoted in ampere-hours. Watt-hour is just ampere-hour x voltage.)

Comparison of key parameters

Parameter	Lead Acid	NiCd	NiMH	Alkaline	Li-Ion	Li-Polymer
Cell Voltage (V)	2.0	1.2	1.2	1.5	3.6	3.7
Relative Cost	Low	Moderate	High	Very low	Very high	Very high
Internal Resistance	Low	Very low	Moderate	Varies	High	Low
Self Discharge (%/month)	2% to 4%	15% to 30%	18% to 20%	0.3%	6% to 10%	5%
Cycle Life (Charge Cycles to Reach 80% of Rated Capacity)	500 to 2000	500 to 1000	500 to 800	Low	1000 to 1200	> 1000
Overcharge Tolerance	High	Medium	Low	Medium	Very low	Very low
Energy Density by Volume (Wh/L)	70 to 110	100 to 120	135 to 180	220	280 to 320	~400
Energy Density by Weight (Wh/kg)	30 to 45	45 to 50	55 to 65	80	90 to 110	130 to 200

PYKC 14 June 2018

DE 1.3 - Electronics

Lecture 17 Slide 13

Here is a more detailed table summarising the key parameter range for each type of rechargeable batteries.

It is included here for your reference.

Specifications	Lead Acid	NiCd	NiMH	Li-ion		
				Cobalt	Manganese	Phosphate
Specific energy density (Wh/kg)	30–50	45–80	60–120	150–190	100–135	90–120
Internal resistance ¹ (mΩ)	<100 12V pack	100–200 6V pack	200–300 6V pack	150–300 7.2V	25–75 ² per cell	25–50 ² per cell
Cycle life ⁴ (80% discharge)	200–300	1000 ³	300–500 ³	500–1,000	500–1,000	1,000–2,000
Fast-charge time	8–16h	1h typical	2–4h	2–4h	1h or less	1h or less
Overcharge tolerance	High	Moderate	Low	Low. Cannot tolerate trickle charge		
Self-discharge/month (room temp)	5%	20% ⁵	30% ⁵	<10% ⁶		
Cell voltage (nominal)	2V	1.2V ⁷	1.2V ⁷	3.6V ⁸	3.8V ⁸	3.3V
Charge cutoff voltage (V/cell)	2.40 Float 2.25	Full charge detection by voltage signature		4.20		3.60
Discharge cutoff voltage (V/cell, 1C)	1.75	1.00		2.50 – 3.00		2.80
Peak load current Best result	5C ⁹ 0.2C	20C 1C	5C 0.5C	>3C <1C	>30C <10C	>30C <10C
Charge temperature	–20 to 50°C	0 to 45°C		0 to 45°C ¹⁰		
Discharge temperature	–20 to 50°C	–20 to 65°C		–20 to 60°C		
Maintenance requirement	3–6 months ¹¹ (topping chg.)	30–60 days (discharge)	60–90 days (discharge)	Not required		
Safety requirements	Thermally stable	Thermally stable, fuse protection common		Protection circuit mandatory ¹²		
In use since	Late 1800s	1950	1990	1991	1996	1999

A video on how to choose a battery? (9 min)



PYKC 14 June 2018

DE 1.3 - Electronics

Lecture 17 Slide 14

This video can be found on:

<https://www.youtube.com/watch?v=saxYiIJ7yw>

